



Office de la Propriété
Intellectuelle
du Canada

Un organisme
d'Industrie Canada

Canadian
Intellectual Property
Office

An agency of
Industry Canada

CA 2407113 A1 2003/04/25

(21) 2 407 113

(12) DEMANDE DE BREVET CANADIEN
CANADIAN PATENT APPLICATION

(13) A1

(22) Date de dépôt/Filing Date: 2002/10/09

(41) Mise à la disp. pub./Open to Public Insp.: 2003/04/25

(30) Priorité/Priority: 2001/10/25 (10/001,325) US

(51) Cl.Int.⁷/Int.Cl.⁷ A63B 71/14, A41D 13/08, A41D 19/015

(71) Demandeur/Applicant:
HILLERICH & BRADSBY CO., US

(72) Inventeur/Inventor:
KLEINERT, JAMES M., US

(74) Agent: FURMAN & KALLIO

(54) Titre : GANT A BLOQUEUR DE GARDIEN DE BUT DE HOCKEY

(54) Title: HOCKEY GOALTENDER BLOCKER GLOVE

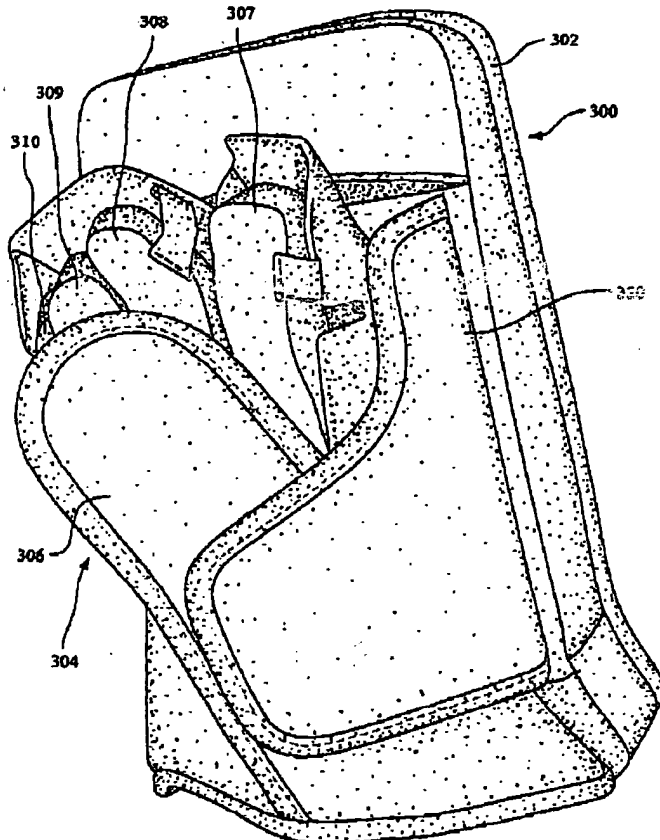

(57) Abrégé/Abstract:

A batting glove includes a plurality of finger elements, a thumb element, a top portion, and a lower portion. The finger elements cover fingers, the thumb element covers a thumb, the top portion covers a back side of the hand, and the lower portion covers a palm of the hand. Preselected thickness of preselected materials are included in order to protect the bones, ligaments, pulleys,



(57) Abrégé(suite)/Abstract(continued):

tendons, etc. of a wearer from direct shock, and to distribute stress along the hand. A hockey goaltender's blockers glove includes a blocker pad with a glove for receiving a human hand attached thereto, the glove including a thumb stall and a plurality of finger stalls wherein the thumb stall is provided with a shock absorbing pad to protect the A-2 pulley, the shock absorbing pad being positioned above the metacarpal of the thumb and below the center axis of rotation of the metacarpalphalangeal joint of the thumb and below the center axis of rotation of the interphalangeal joint. Additional protective padding may extend to other areas above and below the center axis, the distal interphalangeal joint, the proximal interphalangeal joint, and the metacarpalphalangeal joints of the fingers.

ABSTRACT OF THE DISCLOSURE

A batting glove includes a plurality of finger elements, a thumb element, a top portion, and a lower portion. The
5 finger elements cover fingers, the thumb element covers a thumb, the top portion covers a back side of the hand, and the lower portion covers a palm of the hand. Preselected thicknesses of preselected materials are included in order to protect the bones, ligaments, pulleys, tendons, etc. of a
10 wearer from direct shock, and to distribute stress along the hand.

A hockey goaltender's blocker glove includes a blocker pad with a glove for receiving a human hand attached thereto, the glove including a thumb stall and a plurality of finger
15 stalls wherein the thumb stall is provided with a shock absorbing pad to protect the A-2 pulley, the shock absorbing pad being positioned above the metacarpal of the thumb and below the center axis of rotation of the metacarpalphalangeal joint of the thumb and below the center axis of rotation of
20 the interphalangeal joint. Additional protective padding may extend to other areas above and below the center axis, the distal interphalangeal joint, the proximal interphalangeal joint, and the metacarpalphalangeal joints of the fingers.

25

HOCKEY GOALTENDER'S BLOCKER GLOVE

BY

JAMES M. KLEINERT

5

CROSS REFERENCE TO RELATED APPLICATIONS

10

15

BACKGROUND OF THE INVENTION

1. Field of the Invention

This invention relates to gloves for the human hand which are worn when playing sports such as baseball, softball, and the like. In one aspect, this invention relates to a batting glove specifically designed to improve grip, comfort, protection, and performance of a wearer. However, this invention has broader implications and may be advantageously employed in other applications requiring protection of the hands. More particularly, this invention relates to a hockey goaltender's blocker glove which includes padding in selected areas to provide protection of the hand during use by the wearer.

20

25

2. Description of Related Art

Glove construction for protection of the human hand is well known. In addition, there are a number of patents which teach gloves claimed to be particularly useful as batting

gloves. For example, U.S. Patent No. 3,175,226 teaches a dress glove construction which completely covers the fingers and which includes resiliently expandable materials in selected areas to accommodate hands of different sizes. In contrast, U.S. Patent No. 4,561,122 teaches a protective glove which has a wrap around construction for a protective glove which leaves the thumb and fingers ends exposed. U.S. Patent No. 5,345,609 teaches a protective glove which includes shock absorbing cells disposed at selected portions along the top of the glove. U.S. Patent No. 5,790,980 teaches a hand glove with a polyurethane foam pad in the palm portion of the glove. Other references attempt to provide a sport glove for supporting and stabilizing the wrist and hand. Current gloves protect the bony prominence areas of the hand. Although hand protection from direct shocks and abrasions is found in gloves of the current art, what is needed is a batting glove which provides improved grip, comfort and performance by unloading bony prominences, unloading pulleys and tendons, and improving finger and knuckle motion of the hand of a wearer by providing preselected thicknesses of preselected materials specifically chosen to protect the wearer from injury from distributed shocks in hitting a ball with a bat, and the attendant risk of long-term injury to the aforementioned bones, ligaments, pulleys, tendons, etc., by repetitive swinging of bats and hitting of balls.

Also, hockey goaltender's blocker gloves for use, particularly in ice hockey and other sports which require the player to protect his arm from high flying objects, such as

pucks or the like are well known. These blocker gloves are provided on the back or dorsal side of the hand with a blocker pad, usually of substantially rectangular shape which extends longitudinally of the glove covering the back of the hand as well as the forearm. These blocker pads are designed to control the reflective direction of a hockey puck which is directed towards the goal wherein the goaltender prevents the puck from entering the goal. The blocker pad generally has a thick leather skin at the facing thereof and has thereunder a plurality of layers of padding material. On the palmar side of the blocker glove is a stick glove portion designed to receive the thumb and fingers of the hand and to grip a hockey stick. However, there have been problems in the design of the palmar side of the blocker glove in providing protection against "stingers" and yet maintain flexibility of the fingers and rotational movement of the joints.

SUMMARY OF THE INVENTION

In the development of gloves, several key elements are utilized in the design. First, on the dorsal side of the glove, the motion zones are determined by the center axis of rotation of the individual thumb, finger, hand, and wrist joints. These motion zones have been applied to specific joint locations for the particular uses of a designed glove. This helps the flexibility of the glove in relationship to its use. As such, the motion zones are selected in various combinations or even individually depending on the specific task or function of the glove.

Secondly, on the palm side of the glove there are additional motion zones. Again, these motion zones, which also function to decrease glove impedance and improve the breath-ability of the glove, are located specifically in relationship to the center axis of rotation of the finger joints.

Thirdly, again on the palm side of the glove, there are specific areas of padding. The location of the padding is determined by the bone and joint anatomy of the hand, fingers, and thumb. For the hand, the palm pad is placed above the center axis of rotation of the wrist (i.e., just above or distal to the hook of the hamate) and just below the center axis of rotation of the metacarpal heads. These bony landmarks are actually quite prominent in relationship to the surface of the hand. By placing the pads between the bony prominences, these areas of the hand are unloaded. The type of pad chosen for the palm is specific to its function. Other applications require some adjustments to the pad, but the basic premise still remains to unload the bony prominences of the hand in relationship to the required object to be held.

The pads for the fingers are placed again between the bony prominences of each specific finger bone (phalanx). The individual pads of the digits are placed over the relatively flat portion of the phalanx and as such, between the joints that are present on each side of the respective phalanx. The pad does not cover the area near the center axis of rotation. Again, this unloads these bony areas and leads to more even distribution of force across the digit. In other words,

decreased areas of concentrated pressure, i.e, over the bony prominences and individual phalanxes will experience less discomfort. Of course, improved comfort leads to better grip and performance of the specific task in question. The pads on
5 the fingers are placed over the proximal and middle phalanx of each digit. Because of the relative bony and flexor tendon pulley anatomy, these regions correlate with the A2 and A4 pulleys specifically. Furthermore, this placement allows for unrestricted motion of the various finger and hand joints by
10 precisely keeping the pads away from the center axis of rotation (for each specific joint). Depending on the use of the glove, various combinations, or even independent use of these pads could be utilized in glove construction. Additionally, the pads may have different sizes and shapes
15 depending on the application. However, the pads would still be centered primarily between the bony prominences and away from the center axis of rotation for each joint.

The pad for the thumb is placed between the bony prominences of the first phalanx, primarily on the lateral
20 (side) region. Again, the pad is located above the center axis of rotation of the metacarpalphalangeal joint of the thumb and below the center axis of rotation of the interphalangeal joint of the thumb. Other applications to this pad placement are quite numerous. Even this pad could be
25 an application in combination with all, some, one, or none of the finger and palm pads depending on the task.

Optionally, pads may also be placed over the distal phalanx of each digit, just beyond the bony prominences. This

pad would be above (distal) the center axis of rotation of the distal interphalangeal joint of the respective finger. As such, three pads could be placed over each finger depending on the use required for the glove.

5 The motion zone for the wrist area is also determined by the center axis of rotation of the wrist joint. This allows for essentially full motion of the wrist, while at the same time, avoiding dislodgement of the glove from the player's hand. Not all gloves require or benefit from a wrist motion
10 zone. However, a combination of the finger, thumb, hand, and wrist motion zones determined by the joints center axis of rotation may be utilized for various glove applications.

 An object of the present invention is to provide a batting glove which takes stress off of selected parts of the
15 human hand.

 Another object of the present invention is to provide a batting glove having preselected materials of construction in different areas of contact with the human hand.

 A further object of the present invention is to provide a
20 batting glove having preselected thicknesses of preselected materials of construction in different areas of contact with the human hand.

 Yet another object of the present invention is to provide a batting glove which uses different materials to allow wrist
25 motion, unload bony prominences, improve finger and knuckle motion, and protect the back of the hand.

Also, an object of the present invention is to provide a goaltender's blocker glove which takes stress off selected parts of the human hand when the glove is in use.

Another object of the present invention is to provide a
5 hockey goaltender's blocker glove with padding added at selected areas of the hand for protecting selected anatomical portions of the human hand and yet allow the fingers and the joints of the hand to have flexibility and mobility.

In one aspect, the present invention provides a batting
10 glove including preselected material in preselected thicknesses to fill in the soft spots surrounding the bony prominences of the hand, to unload the pulleys and tendons, and to take stress off of selected parts of the hand. Specifically, 2-Way SPANDEX® materials are used in the wrist
15 motion zone of the glove; thin elastic material such as LYCRA® is used in the area of the finger joints and knuckles; synthetic material such as JANEC SUPER® is used in the area of the dorsal side of the fingers; a cabretta skin protective covering is used for selected parts of the hand; rubber foam
20 protective padding is placed at selected contact areas, and soft padding such as terry cotton is placed inside the glove in selected areas.

More particularly, the present invention provides a
25 hockey goaltender's block glove which includes a glove segment and a blocker pad. The glove segment has a dorsal side and a palmar side with a top glove panel covering the palmar side of the human hand which includes the palm, thumb and fingers and a bottom glove panel sized to cover the back, thumb and

fingers of the dorsal side of the human hand. The top and bottom panels which make up the glove segment are secured along each panel's periphery to define a glove body with an opening therein to receive a human hand. The blocker pad is provided with a front face and an opposed back wherein the dorsal side of the glove segment is attached to the blocker pad back. Particularly, the glove segment is provided with a thumb and fingers section for receiving a thumb and fingers of the human hand. Shock absorbing pads are provided to overlie selected areas defined by the location of anatomical parts of the human hand when inserted into the glove. Specifically, the shock absorbing padding, which is usually a foam rubber or another foam elastomeric material of approximately 1/4" in thickness, overlies at least the A2 pulley region of the thumb which is between the metacarpalphalangeal joint and the center axis of rotation of the interphalangeal joint of the thumb. Other areas of shock absorbing padding may be added to overlie the middle phalanx of the index finger above the proximal interphalangeal joint and below the center axis of rotation of the distal interphalangeal joint, to overlie the proximal phalanx of the long finger above the metacarpal-phalangeal joint and below the center axis of rotation of the proximal interphalangeal joint, as well as overlying the proximal phalanx of the ring finger and the small finger above the metacarpalphalangeal and below the center axis of rotation of the proximal interphalangeal joint. Additionally the shock absorbing padding may overlie areas of the metacarpals of the

index, long, ring, and small fingers below the center axis of rotation of the metacarpalphalangeal joints.

Further objects and advantages of this invention will appear from the following description and appended claims, reference being had to the accompanying drawings forming a part of the specification wherein like references designate corresponding parts into several views.

BRIEF DESCRIPTION OF THE DRAWINGS

A better understanding of the invention will be had upon reference to the following description in conjunction with the accompanying drawings in which like numerals refer to like parts throughout the several views and wherein:

Fig. 1 is a bottom schematic anatomical view of the bones of a right-side human hand showing the palm-side details;

Fig. 1A is a bottom schematic anatomical palm-side view of the bones, and selected details of the pulleys and tendons of a right-side human hand;

Fig. 2 is a top view of a batting glove of a preferred embodiment of the present invention showing the dorsal-side details and seen overlaying the skeletal structure of a right-dorsal-side human hand;

Fig. 3 is a bottom view of a batting glove of a preferred embodiment of the present invention showing the palm-side details and seen overlaying the skeletal structure of a right-palm-side human hand;

Fig. 3A is a bottom view of another batting glove of a preferred embodiment of the present invention showing relevant palm-side details;

Fig. 4 is a radial side view of a batting glove of a preferred embodiment of the present invention showing relevant details and seen overlaying the skeletal structure of a right-side human hand;

5 Fig. 5 is an exploded view of some of the major components of a batting glove of a preferred embodiment of the present invention;

Fig. 6 is a perspective view of a blocker glove of the present invention with a goaltender shown in phantom lines;

10 Fig. 7 is a perspective view of the blocker glove of Fig. 6 showing the palm side of the glove;

Fig. 8 is a bottom view of a preferred hockey goaltender's blocker glove showing the palmar-side details and seen overlaying the skeletal structure of a right-palmar-side human hand inserted into the glove showing location for shock absorbing pads;

15 Fig. 9 is a bottom view of the hockey goaltender's blocker glove;

20 Fig. 10 is a sectional view taken along line 10-10 of Fig. 9; and,

Fig. 11 is a sectional view taken along line 11-11 of Fig. 9.

DESCRIPTION OF THE PREFERRED EMBODIMENTS

A. BATTING GLOVE

25 Fig. 1 is a schematic anatomical view of the bones of a right human hand 10 looking at a palm 18 side. Shown are the radius 20, ulna 21, radiocarpal joint (RC) 23', distal radio ulnar joint (DRUJ) 22, wrist 12, thumb 64, index finger 65,

long finger 66, ring finger 67, and small finger 68. The carpus 69

comprises eight carpal bones, seven of which are shown in Fig. 1 and includes the hamate bone 71 with its hook-like protrusion, the scaphoid 24' and the lunate 25.

5

The thumb 64 is comprised of the distal phalanx 51, the interphalangeal joint (IP) 46, proximal phalanx 41, diaphysis of proximal phalanx 41', metacarpalphalangeal joint (MCP) 36, metacarpal 31, and carpometacarpal joint (CMC) 26.

10

The index finger 65 is comprised of the distal phalanx 60, distal interphalangeal joint (DIP) 56, middle phalanx 52, proximal interphalangeal joint (PIP) 47, proximal phalanx 42, metacarpalphalangeal joint (MCP) 37, metacarpal 32, and carpometacarpal joint (CMC) 27.

15

The long finger 66 is comprised of the distal phalanx 61, distal interphalangeal joint (DIP) 57, middle phalanx 53, proximal interphalangeal joint (PIP) 48, proximal phalanx 43, metacarpalphalangeal joint (MCP) 38, metacarpal 33, and carpometacarpal joint (CMC) 23.

20

The ring finger 67 is comprised of the distal phalanx 62, distal interphalangeal joint (DIP) 58, middle phalanx 54, proximal interphalangeal joint (PIP) 49, proximal phalanx 44, metacarpalphalangeal joint (MCP) 39, metacarpal 34, and carpometacarpal joint (CMC) 24.

25

The small finger 68 is comprised of the distal phalanx 63, distal interphalangeal joint (DIP) 59, middle phalanx 55, proximal interphalangeal joint (PIP) 50, proximal phalanx 45,

metacarpalphalangeal joint (MCP) 40, metacarpal 35, and
carpometacarpal joint (CMC) 30.

Fig. 1A shows the skeletal anatomy, pulley system, and
flexor tendons of the thumb 64 and fingers 65-68 of the right
5 hand 10. The thumb 64 includes the flexor tendon (Flexor
pollicis longus) 200 and the three pulleys 220-224 of the
thumb 64; an A1 pulley 220, A2 pulley 222, and A3 pulley 224.
The A2 pulley 222 is the most important for function and is
attached to the proximal phalanx 41 of the thumb 64. The
10 respective pulleys 230-238 are also shown for each of the:
index finger 65, long finger 66, ring finger 67, and small
finger 68. Each finger 65-68 has five pulleys 230-238; an A1
pulley 230, A2 pulley 232, A3 pulley 234, A4 pulley 236, and
A5 pulley 238. The A2 pulley 232 and A4 pulley 236 are
15 considered to be the most important for function. The A2
pulley 232 is attached to the proximal phalanx 42-45. The A4
pulley 236 is attached to the middle phalanx 52-55. The A1
pulley 230 is near the MCP joint 37-40, the A3 pulley 234 is
near the PIP joint 47-50 and the A5 pulley 238 is near the DIP
20 joint 56-59.

The flexor tendons 202-208 are shown as one unit for each
finger 65-68, but actually there are two flexor tendons to
each unit. They are the flexor digitorum superficialis and
the flexor digitorum profundus (shown as one, 202-208). These
25 tendons 202-208 travel underneath the pulleys 230-238 and the
flexor digitorum profundus tendon attaches to the distal
phalanx 60-63 of each finger 65-68. The tendons 202-208 move
back and forth below the pulleys 230-238, via muscles (not

shown) attached to the proximal end of the tendons. This movement of the tendon 202-208 produces finger 65-68 flexion. The pulleys 230-238 prevent the flexor tendons 202-208 from bowstringing or moving away from the bone with finger 65-68

5 flexion. If the pulleys 230-238 are damaged and no longer function, the tendons 202-208 will bowstring with a resultant significant loss of finger motion as well as grip strength. As such, pulleys 230-238, especially the A2 pulley 232 and the A4 pulley 236, are very important and must be preserved and
10 protected as much as possible. As shown in Fig. 4, protective padding 102 for each finger 65-68 is placed in an anatomically designed fashion over the A2 and A4 pulley regions. When the A2 and A4 pulleys 232 and 236 are preserved, adequate finger 65-68 motion and grip strength is maintained.

15 In Figs. 2-5, a preferred batting glove 80 is provided for either a right, left, or both human hand(s) 10, as desired. A glove 80 for a left hand 10 utilizes symmetrical placement of the elements, materials, and thicknesses herein described.

20 Fig. 2 shows details of a dorsal side of a batting glove 80 to cover a human hand 10 and seen overlaying the skeletal structure and skin outline of a right-dorsal-side human hand 10.

The batting glove 80 has a plurality of finger elements 25 82, a thumb element 84, a top portion 86, and a lower portion 88 (see Figs. 3-5), wherein the finger elements 82 cover fingers 65-68. The thumb element 84 covers a thumb 64, and

the top portion 86 covers a back side 16 of the hand 10. The lower portion 88 covers the palm side 18 of the hand 10.

An elastic band 90 is attached to the top portion 86 and to the lower portion 88. The elastic band 90 includes a
 5 securing means in the form of a hook 92 and loop 94 fastener for retention above a human wrist 12.

The top portion 86 includes elastic material 96, preferably 2-WAY SPANDEX® in the vicinity of the wrist 12 out to the vicinity of the metacarpalphalangeal joints (MCP) 37-40
 10 of the fingers 65-68 of the hand 10. Additionally, a protective covering 98 is centrally located to cover the back side 16 of the hand 10.

The finger elements 82 each include an upper portion 83 which includes synthetic material 100 with openings formed
 15 therein to receive thin elastic material 116 attached to cover the proximal interphalangeal joints (PIP) 47-50, and the distal interphalangeal joint (DIP) 56-59 of each finger 65-68.

As shown in Fig. 3, a lower portion 85 of the finger
 20 elements 82 includes protective covering 98. In addition, protective padding 102 is affixed beneath the protective covering 98 and adjacent to the fingers 65-68, in preselected areas. As shown in Figs. 3 and 4, protective padding 102 and protective covering 98 cover the middle phalanx 52-55 -
 25 specifically the A4 pulley 236 region, and the proximal phalanx 42-45 - specifically the A2 pulley 232 region, of each finger 65-68. Openings are formed in the lower portion 85 to receive thin elastic material 116 attached to cover the palm-

side 18 of the proximal interphalangeal joints (PIP) 47-50, and the distal interphalangeal joints (DIP) 56-59 of each finger 65-68.

The thumb element 84 includes protective covering 98
5 which surrounds the distal phalanx 51, metacarpalphalangeal joint (MCP) 36, proximal phalanx 41, metacarpal 31, and carpometacarpal joint (CMC) 26 of the thumb 64. As shown in Fig. 2, an opening is formed in the protective covering 98 to receive thin elastic material 116 attached to cover the
10 interphalangeal joint (IP) 46 of the thumb 64. Another opening is formed in the protective covering 98 over the metacarpalphalangeal joint (MCP) 36 to receive thin elastic material 116. As shown in Figs. 2-5, a piece of protective padding 102, which is itself covered by thin elastic material
15 116, is affixed to an area on the thumb element 84 and centered on an ulnar border (inside) of the thumb 64 over the diaphysis of proximal phalanx 41' of the thumb 64. The diaphysis of proximal phalanx 41' is found between the
20 metacarpalphalangeal joint (MCP) 36 and interphalangeal joint (IP) 46 of the thumb 64.

Referring again to Fig. 3, the bottom portion 88 includes elastic material 96 in the vicinity of the wrist 12. Out from the wrist 12 area, the bottom portion 88 includes protective covering 98 continuing out to the vicinity of the
25 metacarpalphalangeal joints (MCP) 36-40 and located to cover the palm 18 of the hand 10. A piece of protective padding 102 is affixed to a central palm 18 area underneath the protective covering 98 and placed at a preselected distance below a

center axis of rotation of the metacarpalphalangeal joints (MCP) 37-40 and extending to a preselected distance above the hook of the hamate 71.

5 As shown in Fig. 3A, another preferred embodiment of the batting glove 80 is similar to the glove 80 of Fig. 3, but is distinguished wherein a central portion 103 of the central palm 18 area is provided having no protective padding 102 and abutting two separate sections, a first section 105, and a
10 section 107 include affixing protective padding 102 underneath the protective covering 98. The central portion 103 includes protective covering 98, but no protective padding 102. When viewed as in Fig. 3A, an overall outline of the central palm 18 area is similar to that of the glove of Fig. 3, except that
15 the central portion 103 appears to be relieved or depressed in relation to the first section 105 and the second section 107.

Referring back to Fig. 3, a first web 120 is formed in the area where the thumb element 84 is in proximity to the index finger 65. An additional piece of protective covering
20 98 (thereby creating a double thickness of protective covering 98) is affixed over the first web 120. A piece of protective padding 102 covered by thin elastic material 116 is affixed over the additional piece of protective padding 98 over the first web 120 to cover an area which is contacted by
25 protective padding 102 of the thumb element 84. When the glove 80 is worn by a wearer, the bottom portion 88 contacts the remainder of the palm 18.

Referring to Fig. 5, the bottom portion 88 is attached to the top portion 86 to enable an entire covering of the palm 18 and the back side 16 of the hand 10 along an outer periphery having at selected locations a plurality of finger openings 110, a thumb opening 112, and a main opening 130. Second, third and fourth webs, 122, 124, and 126, respectively, are formed between adjacent fingers 65-68. The finger elements 82 are fixedly attached to each of the finger openings 110. The batting glove 80 further provides the finger elements 82 with elastic webbing material 104 affixed laterally therebetween beginning at a tip of the index finger 65 down to the second web 122, running up to the long finger 66 and continuing likewise terminating at the tip of the small finger 68 just past the fourth web 126. Soft padding 99 such as terry cotton is placed as desired inside of the batting glove to cover the thicker protective padding 102, preferably in the areas of the palm 18 and pulleys of the fingers 65-68, and to provide for the comfort of the wearer.

Materials used in manufacture are preselected to achieve various goals as follows:

Synthetic material 100, such as, for example, JANEC SUPER® is used dorsally over the fingers 65-68 of the hand 10;

2-Way Elastic material 96, such as, for example, 2-WAY SPANDEX® is used in motion zones of the hand 10 to allow glove 80 movement;

Thin elastic material 116, such as, for example, LYCRA® is used to cover areas on the glove 80 based on centers of

axes of rotation of all joints of the fingers 65-68 and thumb 64 of the hand 10;

Protective covering 98, such as, for example, cabretta skin (Indonesian sheep skin) is used to provide for protection from abrasion and direct shock applied to the hand in gripping a bat (not shown) and hitting a ball (not shown) with the bat; and,

Protection padding 102, such as, for example, rubber foam of 1/16" in thickness, is used to enhance a gripping surface of the fingers 65-68, specifically the regions of the A2 pulley 232 and A4 pulley 236, and in the palm 18 and first web 120 in order to reduce the most severe of shocks transmitted to the hand 10.

The disclosure given is applicable not only to batting gloves, but also to gloves intended for use in various other activities such as, for example, golf, and working in the outdoors to include gardening. Protection for the hands 10 during use in such activities is achieved by measures such as, for example, varying quantity, placement, thickness, dimensions, and elastic qualities of pads, coverings, elastic materials and openings, as appropriate.

B. BLOCKER GLOVE

The goaltender's blocker glove identified by the numeral 300 is shown in Figs. 6 and 7. A blocking pad 302 covers a major portion of the hand, wrist, and forearm of the goalie and may be of any conventional shape but is shown as being rectangular with a preselected thickness of padding material 314 (Fig. 10) within the cover provided, the cover being an

enclosed sewn construction including a back cover portion 316 and a face cover portion 318. The cover may be made of any conventional durable and flexible material with one preferred embodiment being of a nylon that exhibits both superior
5 abrasion and tear resistance and easily conventionally cut and sewn in the manner of any fabric material. A glove 304 is shown affixed by any well known means to the back cover 316 and includes a thumb portion 306, an index finger portion 307, a long finger portion 308, a ring finger portion 309, and a
10 small finger portion 310. The thumb portion 306 extends around the finger portions and wrist to provide extra padding over the sensitive wrist found in the index finger regions and is folded over to protect the wrist and lower portion of the palmar side of the hand. Additional wrist padding may also be
15 provided to fit over the wrist portion of the user and the glove may be of any conventional size and shape known in the art.

As best shown in Figs. 8-11, a preferred hockey
goaltender-blocker glove 300 is provided for the right human
20 hand. The glove 304 includes a covering 320 which may be of either unitary construction or include a plurality of sections to cover the finger sections 307-310. The glove covering is made of any suitable material known in the art, such as leather, or the like. Along the bottom portion of the
25 covering 320 is attached a plurality of shock absorbing pads positioned at specific areas to protect, particularly, the A2 pulley region 222 (Fig. 1A) and the proximal phalanx 41 of the thumb above the metacarpalphalangeal joint 36 and below the

center axis of rotation of the interphalangeal joint 46.

Additional padding may be provided to cover the middle phalanx

52 of the index finger above the proximal interphalangeal

joint 47 and below the center axis of rotation of the distal

5 interphalangeal joint as indicated by the numeral 56, as well

as the proximal phalanxes 43, 44, and 45, of the long finger,

ring finger and small finger, respectively. The shock

absorbing padding 195 is provided over the thumb in the A-2

pulley region of the proximal phalanx 41 between the

10 metacarpalphalangeal joint 36 and the center axis of rotation

of the interphalangeal joint 46, as shown in Fig. 2. Padding

190 is positioned above the proximal interphalangeal joint 47

and below the center axis of rotation of the digital

interphalangeal joint as indicated by the numeral 56. Padding

15 191 is positioned above the metacarpalphalangeal joint 38 and

below the center axis of rotation of the proximal

interphalangeal joint as indicated by the numeral 48. Padding

192 is positioned to overlie the proximal phalanx 44 and is

20 positioned between the metacarpalphalangeal joint 39 and the

center axis of rotation of the proximal interphalangeal joint

as indicated at the numeral 49. Padding 193 is positioned to

overlie the proximal phalanx 45 of the small finger above the

metacarpalphalangeal joint 40 and below the center axis of

rotation of the proximal interphalangeal joint as indicated at

25 the numeral 50. Shock absorbing pad 194 may also be provided

to overlie the metacarpals 32, 33, 34 and 35 of the index

finger, the long finger, the ring finger and the small finger.

Shock absorbing pad 194 overlies metacarpals 32, 33, 34, and

35 and is positioned between the carpometacarpal joints 27,
23, 24, and 30 (Fig. 1) and the center axis of rotation of the
metacarpalphalangeal joints of each of the fingers 65, 66, 67,
and 68 also as shown in Fig. 1. The protective shock
5 absorbing padding is placed in the aforementioned anatomically
designed fashion as shown in cut-away of the index finger
section in Fig. 10 to illustrate the pulleys and tendons
regions protected with the motion zones defined by the center
axis of rotation of the appropriate joints being left free.
10 This enables the movement of the fingers and thumb without
adverse effects when in use.

The detailed description is given primarily for clearness
of understanding and no unnecessary limitations are to be
understood therefrom for modifications will become obvious to
15 those skilled in the art upon reading this disclosure and may
be made without departing from the spirit of the invention and
scope of the appended claims.

What Is Claimed Is

1. A goaltender's blocker glove comprising:

a blocker pad;

a glove segment attached to a back

5 side of said blocker pad, the glove
segment having a dorsal side and a palmar
side with a bottom glove panel positioned
to cover the human hand including a palm,
thumb and fingers and a top glove panel
10 sized to cover a back, thumb and fingers
of the dorsal side of the human hand;

a first shock absorbing pad

positioned to overlie an A-2 pulley region
of a thumb between the

15 metacarpalphalangeal joint and the center
axis of rotation of the interphalangeal
joint.

2. The glove of claim 1, including a second protective
pad positioned to overlie the middle phalanx of an index

20 finger above the proximal interphalangeal joint and below the
center axis of rotation of the distal interphalangeal joint.

3. The glove of claim 1, including a third shock
absorbing protective padding positioned to overlie the
proximal phalanx of a long finger and positioned above the
25 metacarpalphalangeal joint and below the center axis of
rotation of the proximal interphalangeal joint.

4. The glove of claim 1, including a fourth shock
absorbing protective pad positioned to overlie the tendons and

pulleys of the proximal phalanx of the ring finger, said shock absorbing pad being positioned to overlie said proximal phalanx above the metacarpalphalangeal joint and below the center axis of rotation of the proximal interphalangeal joint.

5 5. The glove of claim 1, including a fifth shock absorbing protective pad positioned to cover a proximal phalanx of a small finger, said fifth shock absorbing pad positioned to be above the metacarpalphalangeal joint in the center axis of rotation of the proximal interphalangeal joint.

10 6. The glove of claim 1, including a sixth shock absorbing protective pad positioned to cover metacarpals of the index finger, the long finger, the ring finger and the small finger, said sixth shock absorbing pad being positioned above the carpal metacarpal joint and the center axis of
15 rotation of the metacarpalphalangeal joints of said fingers.

7. The glove of claim 1, said protective padding being a foam rubber or a foam elastomeric material.

8. The glove of claim 1, said shock absorbing protective padding being approximately 1/4" thick.

20 9. A goaltender's blocker glove comprising:

 a blocker pad;

 a glove segment attached to a back side of said blocker pad, the glove segment having a dorsal side and a palmar side with a bottom glove panel positioned
25 to cover the human hand including a palm, thumb and fingers and a top glove panel

sized to cover a back, thumb and fingers
of the dorsal side of the human hand;

5 a first shock absorbing protective
pad positioned to cover metacarpals of the
index finger, the long finger, the ring
finger and the small finger, said sixth
shock absorbing pad being positioned above
the carpal metacarpal joint and the center
axis of rotation of the
10 metcarpalphalangeal joints of said fingers
to overlie an A-2 pulley region of a thumb
between the metacarpalphalangeal joint and
the center axis of rotation of the
interphalangeal joint.

15 10. The glove of claim 9, including a second protective
pad positioned to overlie the middle phalanx of an index
finger above the proximal interphalangeal joint and below the
center axis of rotation of the distal interphalangeal joint.

20 11. The glove of claim 9, including a third shock
absorbing protective padding positioned to overlie the
proximal phalanx of a long finger and positioned above the
metacarpalphalangeal joint and below the center axis of
rotation of the proximal interphalangeal joint.

25 12. The glove of claim 1, including a fourth shock
absorbing protective pad positioned to overlie the tendons and
pulleys of the proximal phalanx of the ring finger, said shock
absorbing pad being positioned to overlie said proximal

phalanx above the metacarpalphalangeal joint and below the center axis of rotation of the proximal interphalangeal joint.

13. The glove of claim 9, including a fifth shock absorbing protective pad positioned to cover a proximal
5 phalanx of a small finger, said fifth shock absorbing pad positioned to be above the metacarpalphalangeal joint in the center axis of rotation of the proximal interphalangeal joint.

14. The glove of claim 9, said protective padding being a foam rubber or a foam elastomeric material.

10 15. The glove of claim 9, said shock absorbing protective padding being approximately 1/4" thick.

16. A goaltender's blocker glove comprising:

a blocker pad;

15 a glove segment attached to a back side of said blocker pad, the glove segment having a dorsal side and a palmar side with a bottom glove panel positioned to cover the human hand including a palm, thumb and fingers and a top glove panel
20 sized to cover a back, thumb and fingers of the dorsal side of the human hand;

25 first shock absorbing protective pad positioned to overlie the proximal phalanx of a long finger and positioned above the metacarpalphalangeal joint and below the center axis of rotation of the proximal interphalangeal joint;

a second shock absorbing protective pad positioned to overlie the tendons and pulleys of the proximal phalanx of the ring finger, said shock absorbing pad being positioned to overlie said proximal phalanx above the metacarpalphalangeal joint and below the center axis of rotation of the proximal interphalangeal joint; and

a third shock absorbing protective pad positioned to cover a proximal phalanx of a small finger, said third shock absorbing pad positioned to be above the metacarpal-phalangeal joint in the center axis of rotation of the proximal interphalangeal joint.

18. The glove of claim 16, including a fifth shock absorbing protective pad positioned to cover metacarpals of the index finger, the long finger, the ring finger and the small finger, said sixth shock absorbing pad being positioned above the carpal metacarpal joint and the center axis of rotation of the metacarpalphalangeal joints of said fingers.

19. The glove of claim 16, said protective padding being a foam rubber or a foam elastomeric material.

20. The glove of claim 16, said shock absorbing protective padding being approximately 1/4" thick.

21. The glove of Claim 16, including a sixth shock absorbing pad positioned to overlie an A-2 pulley of a thumb

between the metacarpalphalangeal joint and the center axis of the rotation of the interphalangeal joint of the thumb.

22. A goaltender's blocker glove comprising:

a blocker pad;

5 a glove segment attached to a back side of said blocker pad, the glove segment having a dorsal side and a palmar side with a bottom glove panel positioned to cover the human hand including a palm, thumb and fingers and a top glove panel
10 sized to cover a back, thumb and fingers of the dorsal side of the human hand;

a first shock absorbing pad

15 positioned to overlie the middle phalanx of an index finger above the proximal interphalangeal joint and below the center axis of rotation of the distal interphalangeal joint between the metacarpalphalangeal joint and the center
20 axis of rotation of the interphalangeal joint.

23. The glove of claim 22, including a second shock absorbing protective padding positioned to overlie the proximal phalanx of a long finger and positioned above the
25 metacarpalphalangeal joint and below the center axis of rotation of the proximal interphalangeal joint.

24. The glove of claim 22, including a third shock absorbing protective pad positioned to overlie the tendons and

pulleys of the proximal phalanx of the ring finger, said shock absorbing pad being positioned to overlie said proximal phalanx above the metacarpalphalangeal joint and below the center axis of rotation of the proximal interphalangeal joint.

5 25. The glove of claim 22, including a fourth shock absorbing protective pad positioned to cover a proximal phalanx of a small finger, said fifth shock absorbing pad positioned to be above the metacarpalphalangeal joint in the center axis of rotation of the proximal interphalangeal joint.

10 26. The glove of claim 22, said protective padding being a foam rubber or a foam elastomeric material.

 27. The glove of claim 22, said shock absorbing protective padding being approximately 1/4" thick.

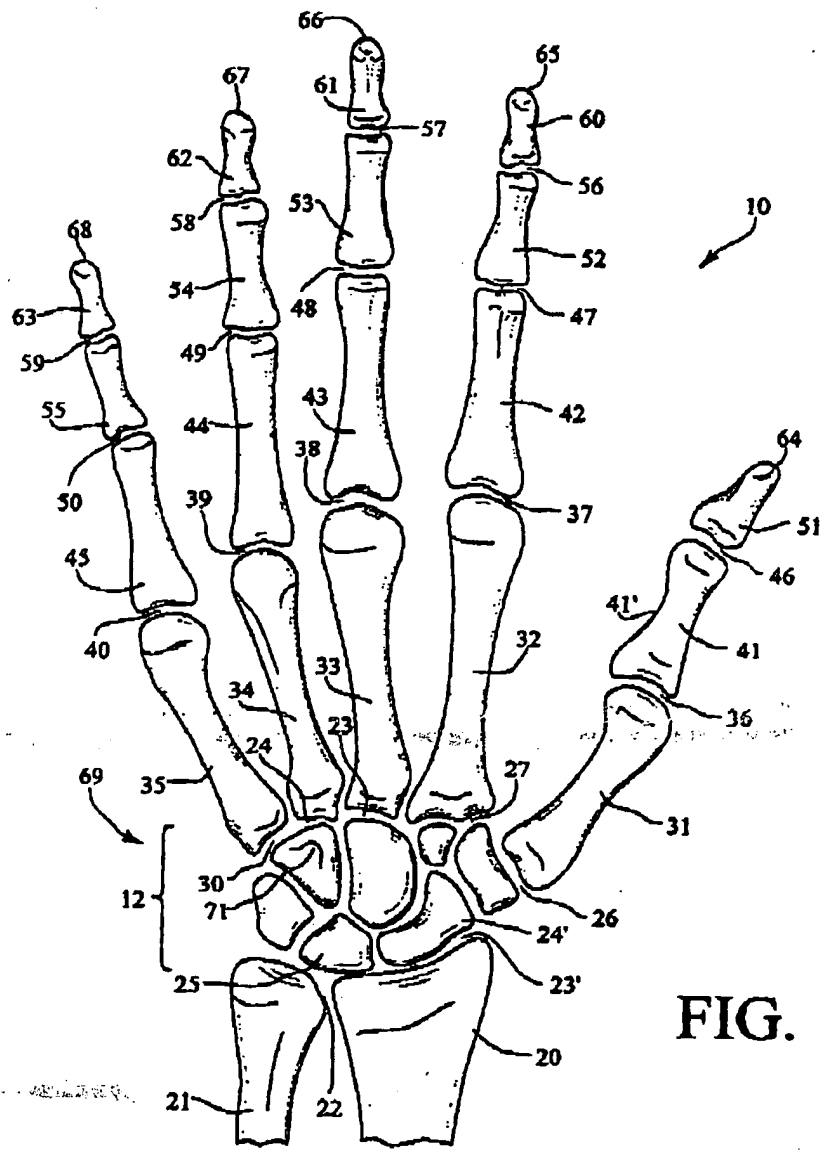

FIG. 1

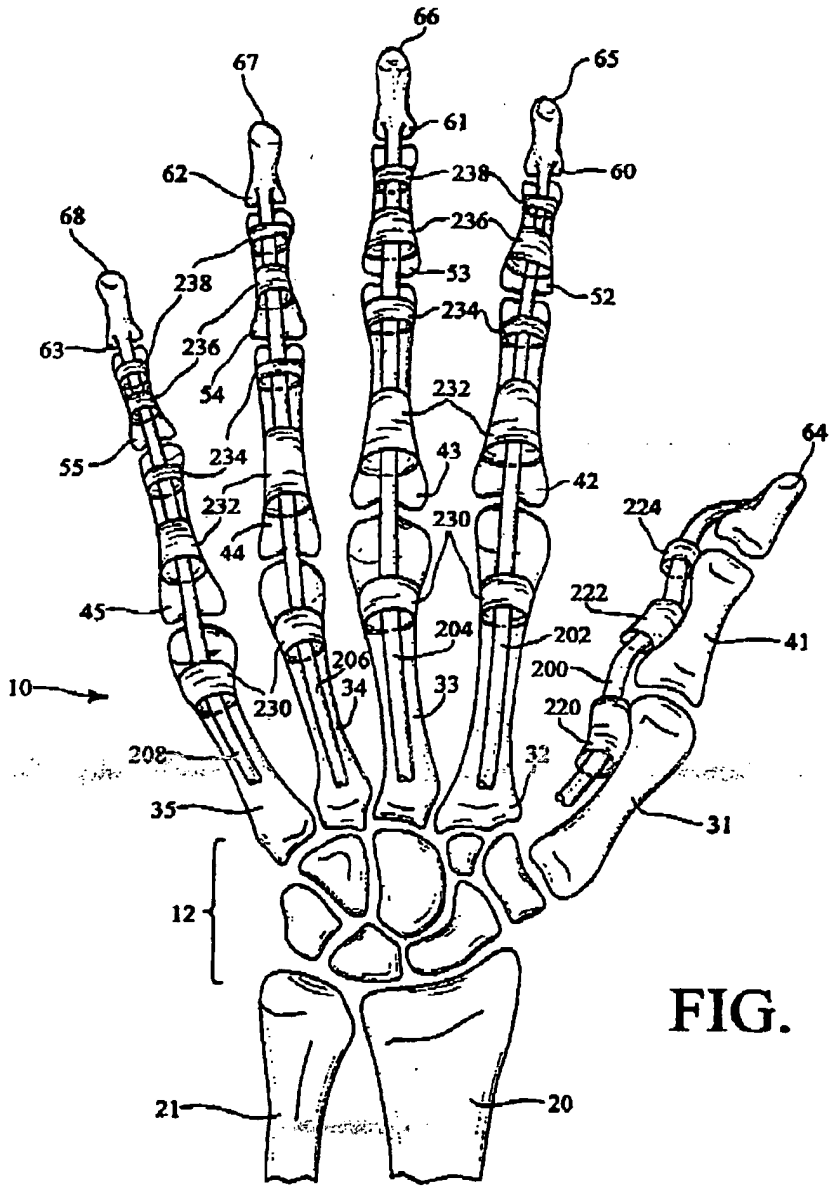

FIG. 1A

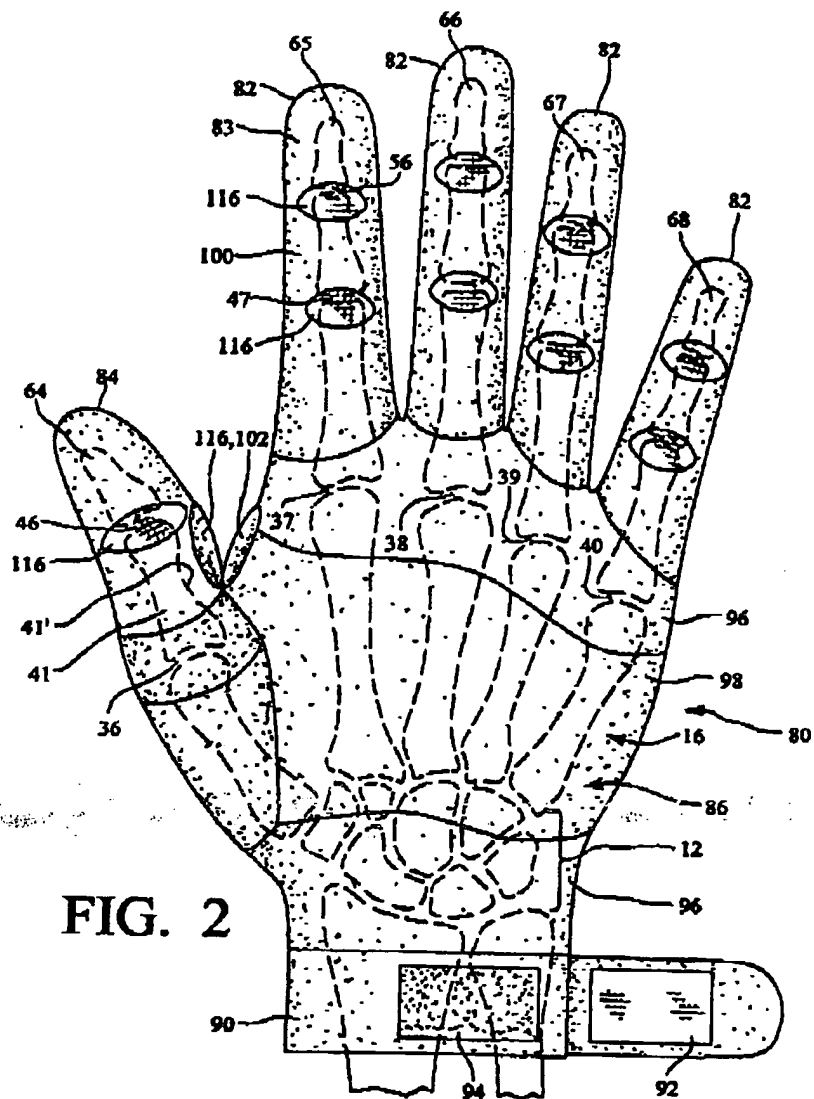
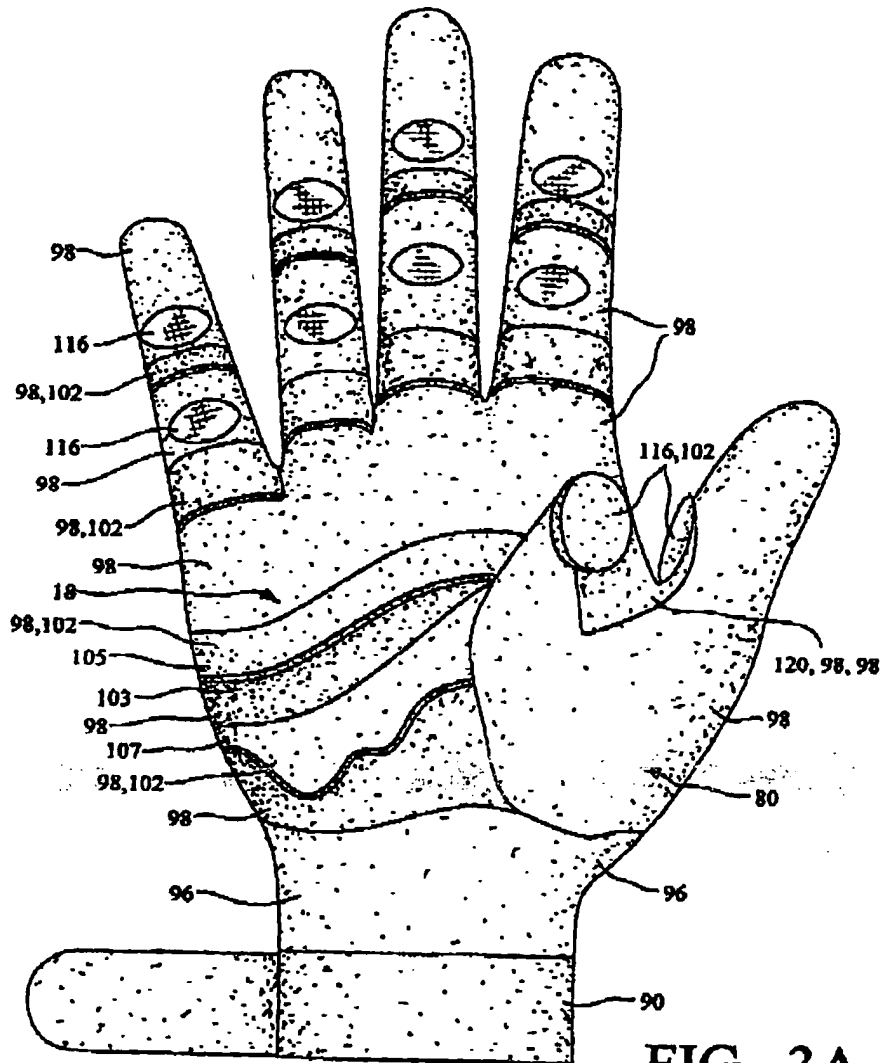

FIG. 2



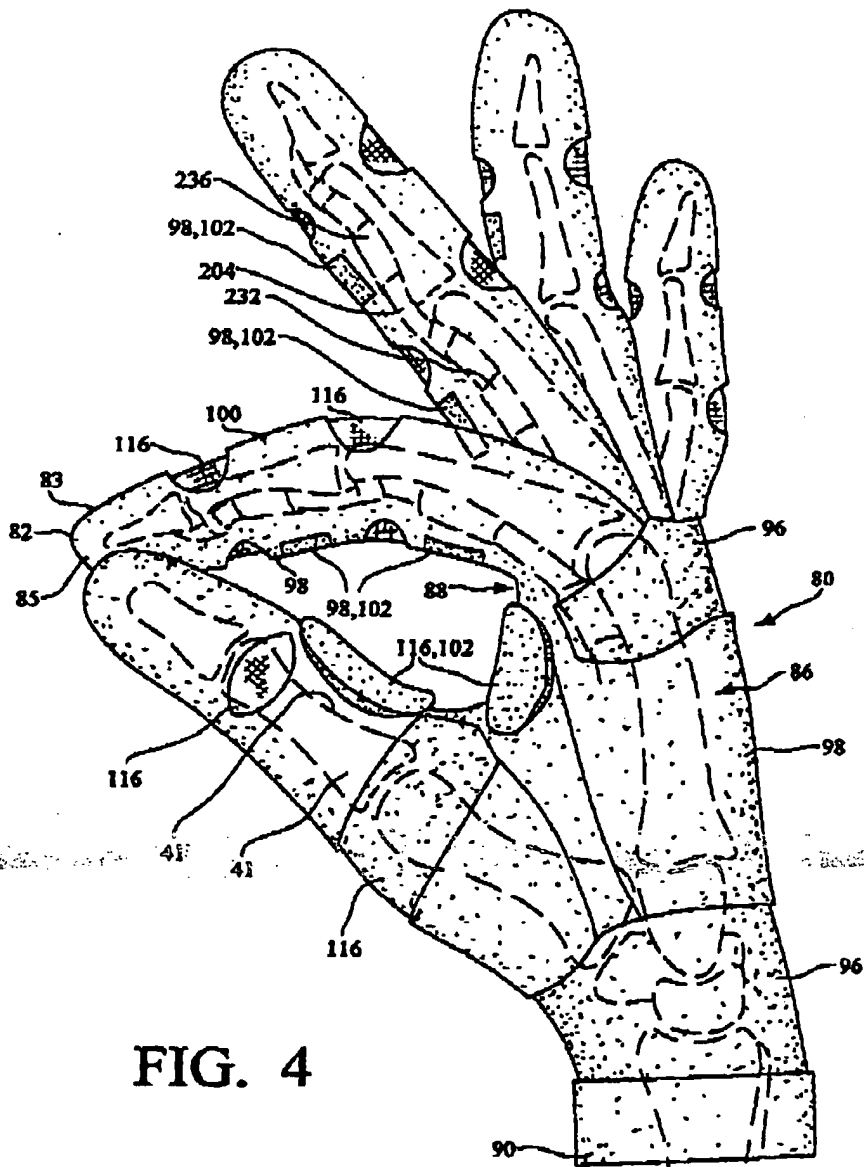

FIG. 4

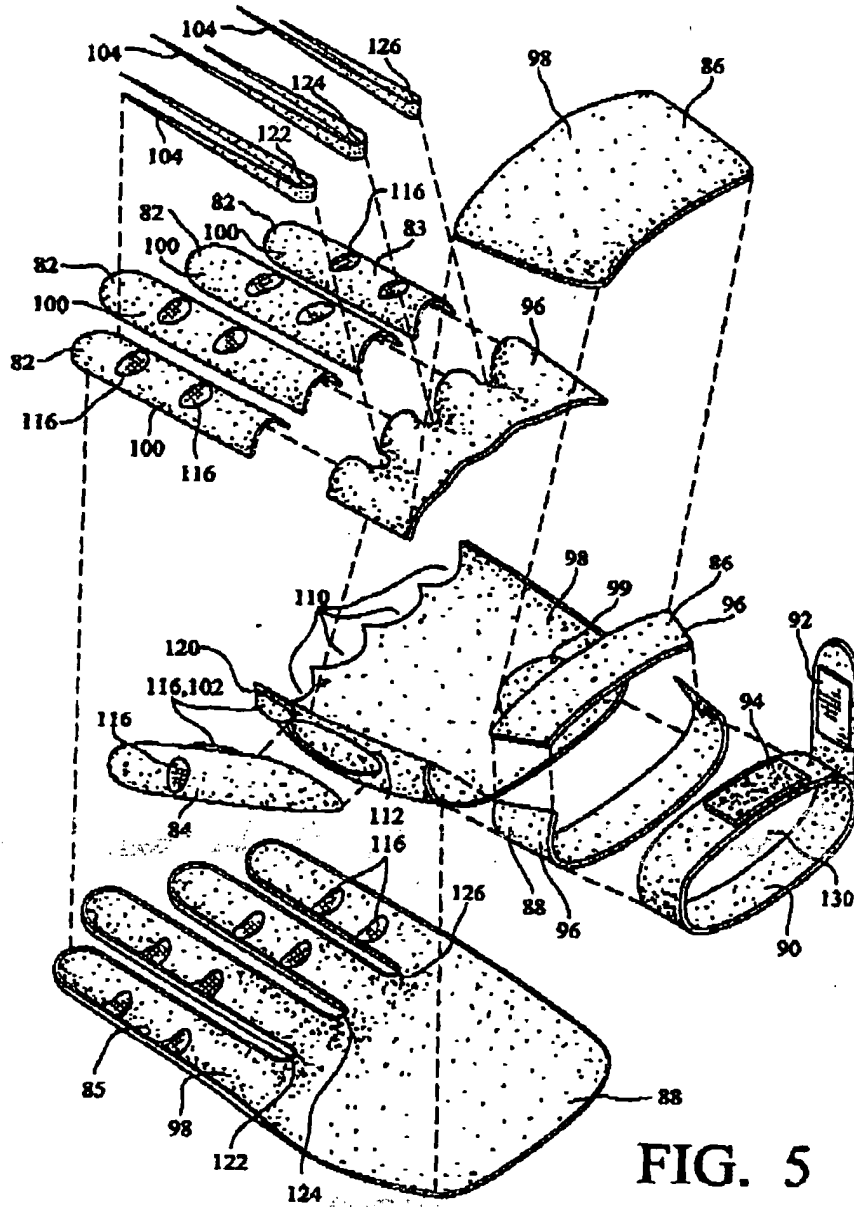

FIG. 5

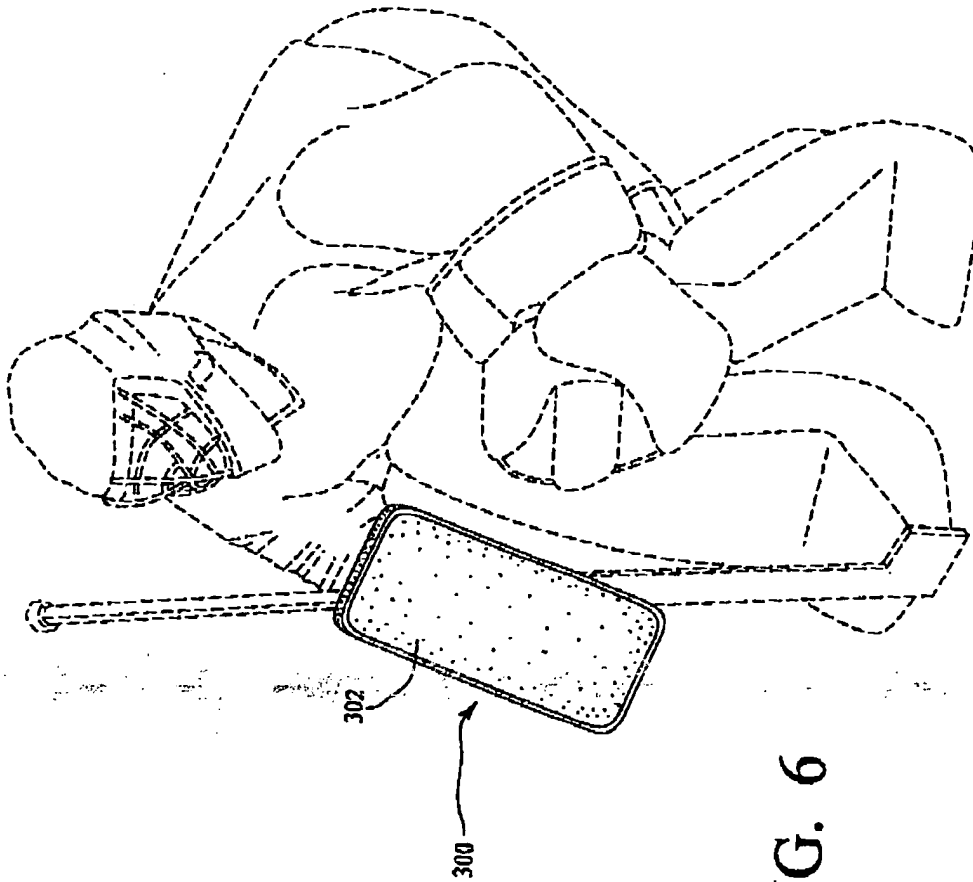

FIG. 6

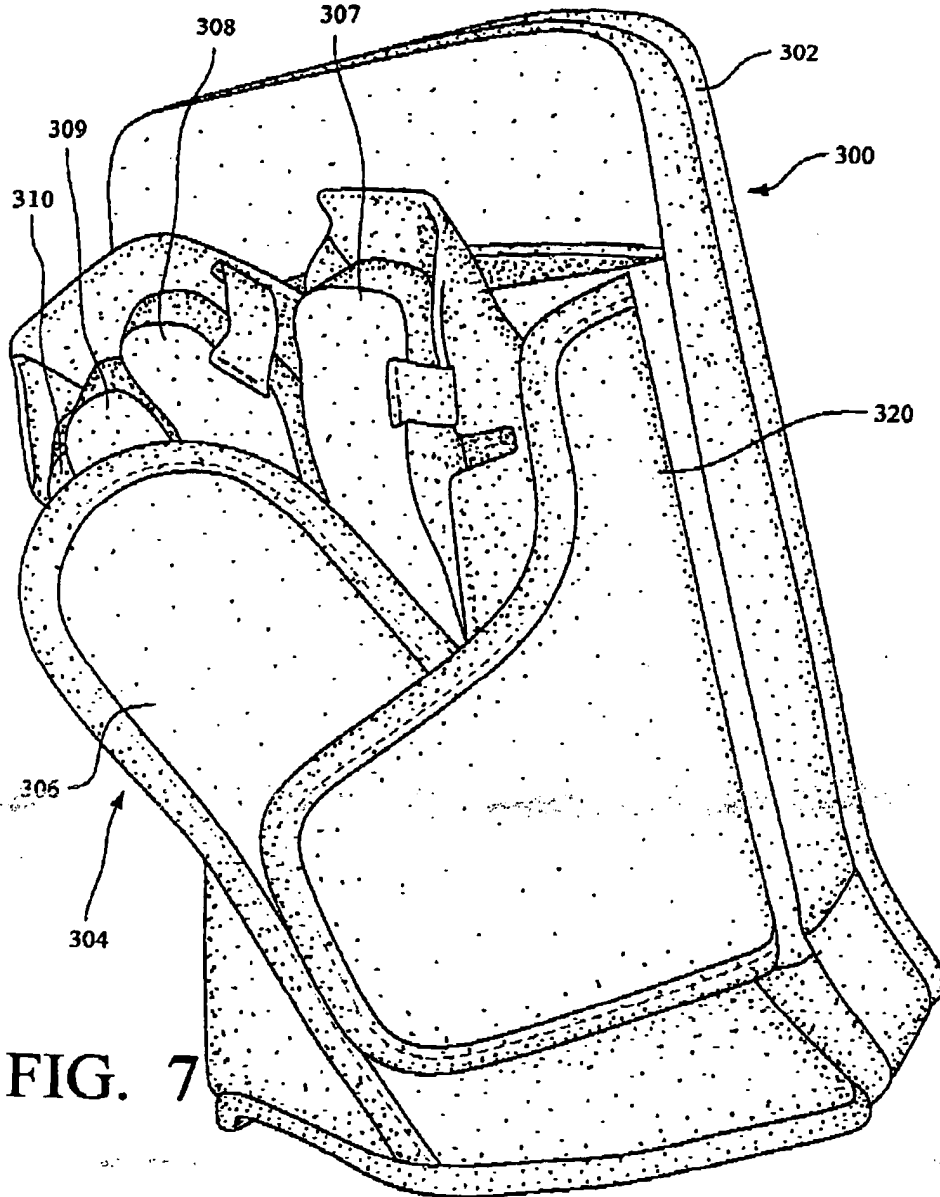

FIG. 7

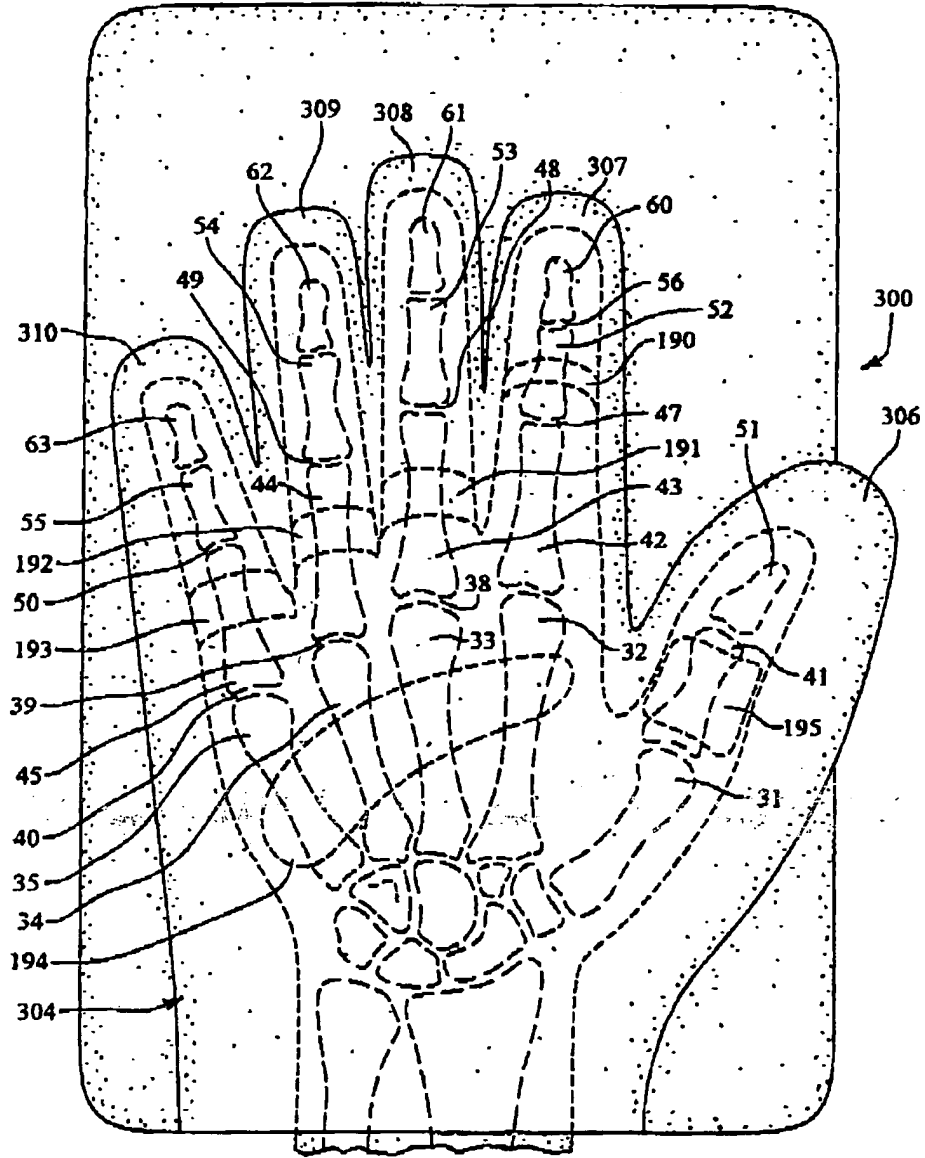

FIG. 8

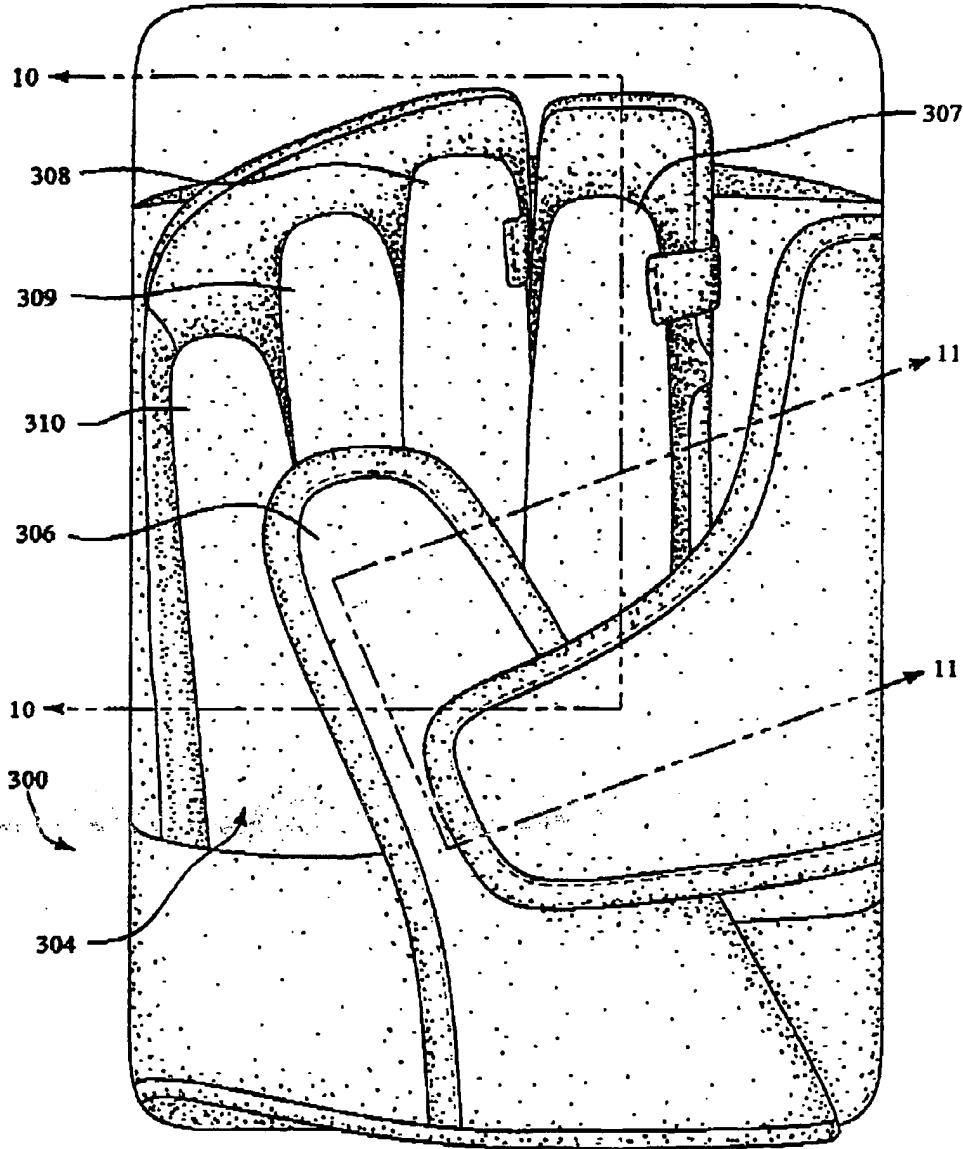

FIG. 9

